



# Solutions 360°

READY WITH FUTURE NEEDS



# INDEX

**01**

About Daikin

**02**

Global Footprint - Providing Solutions Through Air

**04**

The Daikin Difference

**06**

Our Timeline

**08**

Daikin India at a Glance

**10**

Engine of Growth



**12**

R32-The Next Generation Refrigerant

**14**

Ceiling Mounted 3x3 Cassette Type

**24**

Ceiling Concealed Type

**31**

Specifications

**32**

Reasons to Buy Daikin

**5,135** sq mtr

**STATE-OF-THE-ART R&D  
CENTRE AT NEEMRANA,  
RAJASTHAN**

**150+**

**COUNTRY PRESENCE**

# DAIKIN, THE WORLD LEADER IN AIR-CONDITIONING

**BRINGS A WORLD FULL  
OF LOVE TO INDIA WITH  
ITS AIR-CONDITIONING  
SOLUTIONS.**

Known for superior Japanese technology, Daikin promises to spread joy in the air. With a wide range and features like never before, Daikin creates an environment of comfort through efficient air-conditioning. Daikin air-conditioners are manufactured keeping in mind different air-conditioning needs and also space requirements. Our wide range of air-conditioners are easy to install and are apt for residential and commercial usage.

## Solutions 360°

Catering to all light commercial air-conditioning needs with Daikin's flagship products.

# Providing Solutions through Air.

With Comfortable Living Always at the Heart of Our Ideas

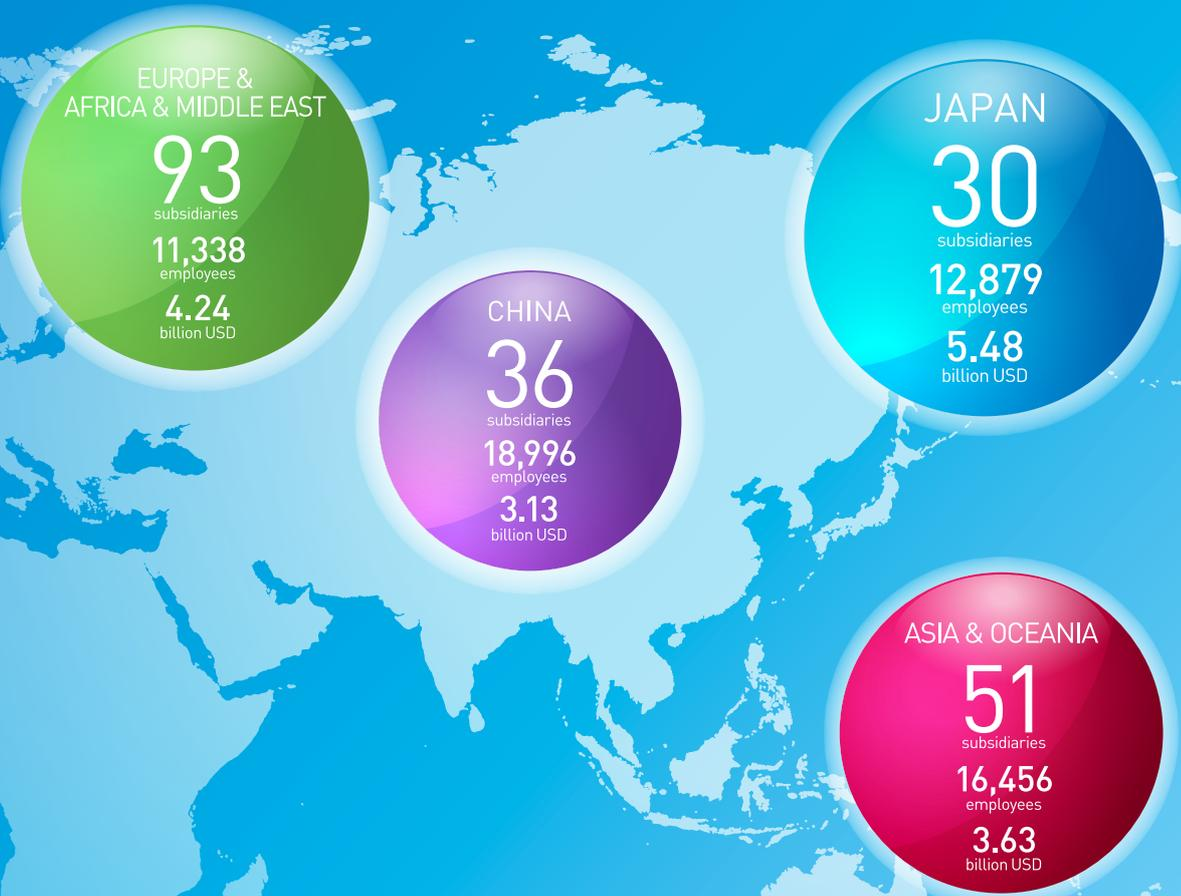

## Corporate Profile



Daikin Industries, Ltd. Osaka

## America



Goodman Manufacturing Company, L.P.  
Address: 817 Sunrise Hwy.,  
Lynbrook, NY 11563

### Network



Daikin Applied Solutions Plaza  
(Jersey City, New Jersey)



Daikin Applied Americas Inc.  
(Minneapolis, Minnesota)



Daikin Texas Technology  
Park (Waller, Texas)



Daikin Applied Development  
Center (Minneapolis, Minnesota)



Daikin Airconditioning  
Mexico, S. de R.L. de C.V.  
(Minneapolis, Minnesota)

## China



Suzhou Factory

### Network



Daikin (China) Investment  
Co. Ltd. (Beijing, Shanghai,  
Guangzhou, Wuhan, Nanjing)



McQuay Central  
Air Conditioning (China)  
Co., Ltd. (Shanghai)

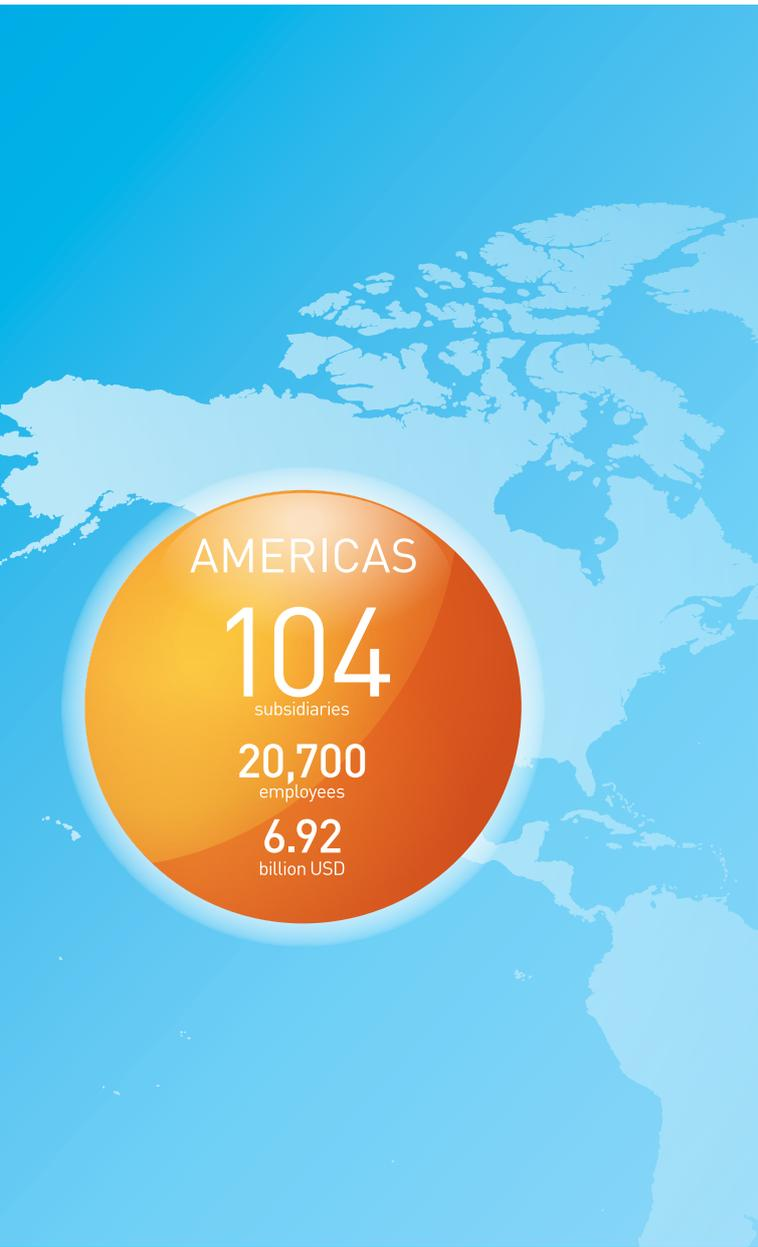

### Middle East & Africa

#### Network



Daikin Middle East and Africa FZE



Daikin Airconditioning Saudi Arabia Co., Ltd.



Daikin Airconditioning Egypt S.A.E



Daikin Airconditioning South Africa



Daikin Airconditioning Solutions, Qatar



Daikin Middle East and Africa FZE AHU Factory

### Japan

#### Domestic Production Bases



Kanaoka Factory, Sakai Plant



Rinkai Factory, Sakai Plant



Yodogawa Plant



Shiga Plant

### Oceania

#### Network



Daikin Australia Pty., Ltd.

### Asean Taiwan & India

#### Network



Daikin Industries (Thailand), Ltd.



Daikin Malaysia Sdn. Bhd



Daikin Airconditioning India Private Ltd.



Daikin Airconditioning Philippines, Inc.



Daikin Malaysia Sales & Services Sdn. Bhd.



PT. Daikin Airconditioning Indonesia



Siam Daikin Sales Co., Ltd.



Daikin Airconditioning India Private Ltd.



Daikin Air Conditioning (Vietnam) Joint Stock Company (Factory)



Acson Malaysia Sales & Service Sdn. Bhd.



Daikin Airconditioning Vietnam JSC



PT. Daikin Applied Solutions Indonesia



Ho Tai Development Co., Ltd. (Taiwan)

### Latin America

#### Network



Group CYVSA Head Office (Mexico City)



Daikin Airconditioning Mexico, S.de R.L. de C.V.



Daikin McQuay Ar Condicionado Brasil Ltda.

### Europe, Russia & CIS

#### Network



Daikin Europe N.V. (Ostend and Brussels, Belgium)



Daikin Applied Europe (Rome, Italy)



Daikin Isitma Ve Sogutma Sistemleri Sanayi Ticaret A.S. (Istanbul and Hendek, Turkey)



# THE DAIKIN DIFFERENCE

As a world leader in technological innovation, we've initiated and funded a wide range of research programmes in areas that directly impact our air-conditioners - ranging from mechanics and electronics to chemicals and fluorocarbons. With this knowledge, we build absolute comfort into every product we develop. Pioneering products include the first packaged air-conditioner in Japan 1951 and the world's first Variable Refrigerant Volume (VRV) system in 1982. Daikin is committed to explore and adopt cutting-edge technology to continually offer value-added and solution-based products and services to customers.



## THE LOGO

The triangle shape represents the integration of three technological areas (mechanics, chemistry and electronics), while the upper left direction of the triangle symbolises Daikin's innovative spirit that aspires toward the future. The two blue colours (corporate colours) used in the corporate logo and the triangle design element befit Daikin's emphasis on intellect and brightness. Black expresses strength, a sense of positive presence and stability.

In all of us,  
a green heart

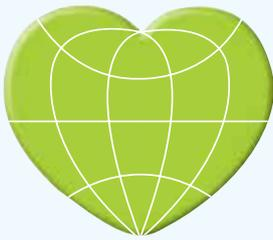

## ENVIRONMENTAL PHILOSOPHY

In February 2002, we created an environmental symbol for the Daikin Group. In environmental protection activities, little efforts that individuals make add up to big things. The symbol, the Earth in the shape of a green heart, represents a determination on the part of each and every employee of Daikin to think green (think of the Earth and take care of the environment).

As we continue developing our business operations in various fields, it is our mission to proactively develop initiatives to respond to environmental issues. Incorporating environmental initiatives throughout our management must be a priority for us. In all aspects of our business operations, including product development, manufacturing and sales, we need to formulate initiatives that sustain and improve the environment. Meanwhile, we need to promote the development of new products and the innovation of technologies that will lead to a more environmentally healthy world.

## PICHONKUN

A mascot that represents Daikin's innovative thrust into the future is called 'PICHONKUN'. The new mascot of Daikin is so named because of the sound it makes. Created in Japan, this dew droplet represents the 'fresh as morning nature' of Daikin's new range of air-conditioners and airpurifiers. PICHONKUN symbolises the best of nature-fresh, natural and eco-friendly.



# OUR TIMELINE

1924-2019

## 1924

Akira Yamada founds the Osaka Kinzoku Kogyosho Limited Partnership.

## 1934

Osaka Kinzoku Kogyo Co. Ltd. is established, with the following corporate logo: Trial manufacture of a methyl chloride type refrigerator succeeds. The refrigerator is named Mifujirator and production begins.

## 1936

The Mifujirator refrigerator is delivered to Nankai Railways for trial use as Japan's first air-conditioner for trains.

## 1991

Daikin America, Inc. and MDA Manufacturing, Inc. are established in the US.

## 1990

Daikin Industries (Thailand) Ltd. is established in Thailand and begins production of air-conditioners.

## 1982

Japan's first VRV system is developed. The industry's first single-screw refrigerator is developed.

## 1992

Daikin Chemical Europe is established in Dusseldorf, Germany.

## 1993

Daikin Airconditioning France S.A. is established in Paris as an air-conditioning system sales company.

## 1995

The industry's first compact room air-conditioner to use a swing compressor to save energy is marketed.

## 2009

Acquired Japan's leading air filter company Nippon Muki Co. Ltd.

## 2008

Receipt of 'Eco Products Awards' Japan's Ministry of the Environment's Minister's Prize for 'Sho-ene Toban', a building air-conditioner remote energy-saving control service.

## 2006

Acquisition of major global air-conditioning manufacturer OYL Industries (Malaysia) with the aim of becoming the No.1 air-conditioning manufacturer. Establishment of Environmental Response Department at Daikin Europe N.V. to take the lead in environmental response in the European region.

## 2012

Acquisition of the major American residential use air-conditioner company, Goodman, to build a solid base for positioning Daikin as the leading company in the global air-conditioner market. Launch of residential air-conditioner featuring the world's first adoption of the next generation refrigerant HFC32.

## 2016

Daikin India starts the production of Non-Inverter Cassette air conditioners.

## 2017

Daikin India starts the production of Inverter Cassette air conditioner.



**1951**

Production of packaged air-conditioners begins.

**1956**

A heat exchanging device is installed on the Soya, an Antarctic research vessel, as a cabin heating system.

**1924**

Residential-use air-conditioners equipped with Japan's first rotary compressor are marketed. The heat-pump type packaged air-conditioner is developed.

**1969**

A multiroom air-conditioning system with a single outdoor unit is developed. A Freon heater is employed in an air-conditioner, combining heating and cooling functions.

**1964**

Cool air service by Daikin Aircon begins at J.N.R. Osaka Station. The air-conditioner system is thereafter installed in major terminals.

**1963**

Osaka Kinzoku Kogyo Co. Ltd. is renamed Daikin Kogyo Co. Ltd. (Renamed Daikin Industries, Ltd. in 1982).

**1997**

All Daikin factories in Japan (Sakai, Yodogawa, Shiga and Kashima) acquire ISO 14001 certification for environmental management. Presented 32nd Chairman's award by the Japan Society for the promotion of the machine industry for Daikin Swing Compressor.

**1998**

The Institute of Electrical Engineers of Japan presented the award to Daikin for the first scroll compressor to be equipped with the Reluctance DC motor. Room air-conditioners employing the R-410A refrigerant are marketed. Daikin Airconditioning Germany GmbH is established in Munich as an air-conditioning system sales company.

**1999**

Daikin Airconditioning Central Europe GmbH is established in Austria as an air-conditioning system sales company.

**2003**

Daikin is ranked 1st in market share of residential use air-conditioners in Japan throughout the fiscal year of 2003.

**2002**

Received the 11th Annual Grand Prize for the Global Environment presented by the NikkanKogyou Shimbun.

**2001**

Established a company for the manufacture and sale of swing compressors in Bangkok, Thailand, called Daikin Compressor Industries Ltd.

**2019**

Daikin completes the acquisition of AHT Group (Austria)



# DAIKIN INDIA AT A GLANCE

Daikin Airconditioning India Pvt. Ltd., a subsidiary of Daikin Industries Ltd., Japan is one of the leading global manufacturers of both residential and commercial air-conditioning systems. Backed by the superior technology, the organisation offers a wide range of energy efficient air-conditioning solutions to customers.

After introducing our superior air-conditioning solutions in India in the year 2000, we gained the trust of our valuable customers with our innovative range of products and dedication towards quality. An ISO 14001 certified company, we remain committed to keep customers at the core of everything we do. Imbued with a 'Quality First' global philosophy, we at Daikin, walk on to realise our dream for a better world.

'Quality First' is clearly reflected in the value delivered such as low noise level, low power consumption, cooling efficiency, ease of installation, high reliability – all targeted to improve the quality of life.

Daikin India's manufacturing plant at Neemrana, Rajasthan aims at creating products that will make people's lives more comfortable.

It is supported by a network of production bases worldwide and showcases the application of advanced technology and equipment. Our comprehensive quality control system features centrally computerised management of quality and production data to facilitate timely production that bears the stamp of excellent quality.

Daikin Neemrana facility incorporates Daikin's global Environmental Management System (EMS) that has been implemented in the factory to promote adapting procedures for refrigerant handling, resource conservation and waste management.

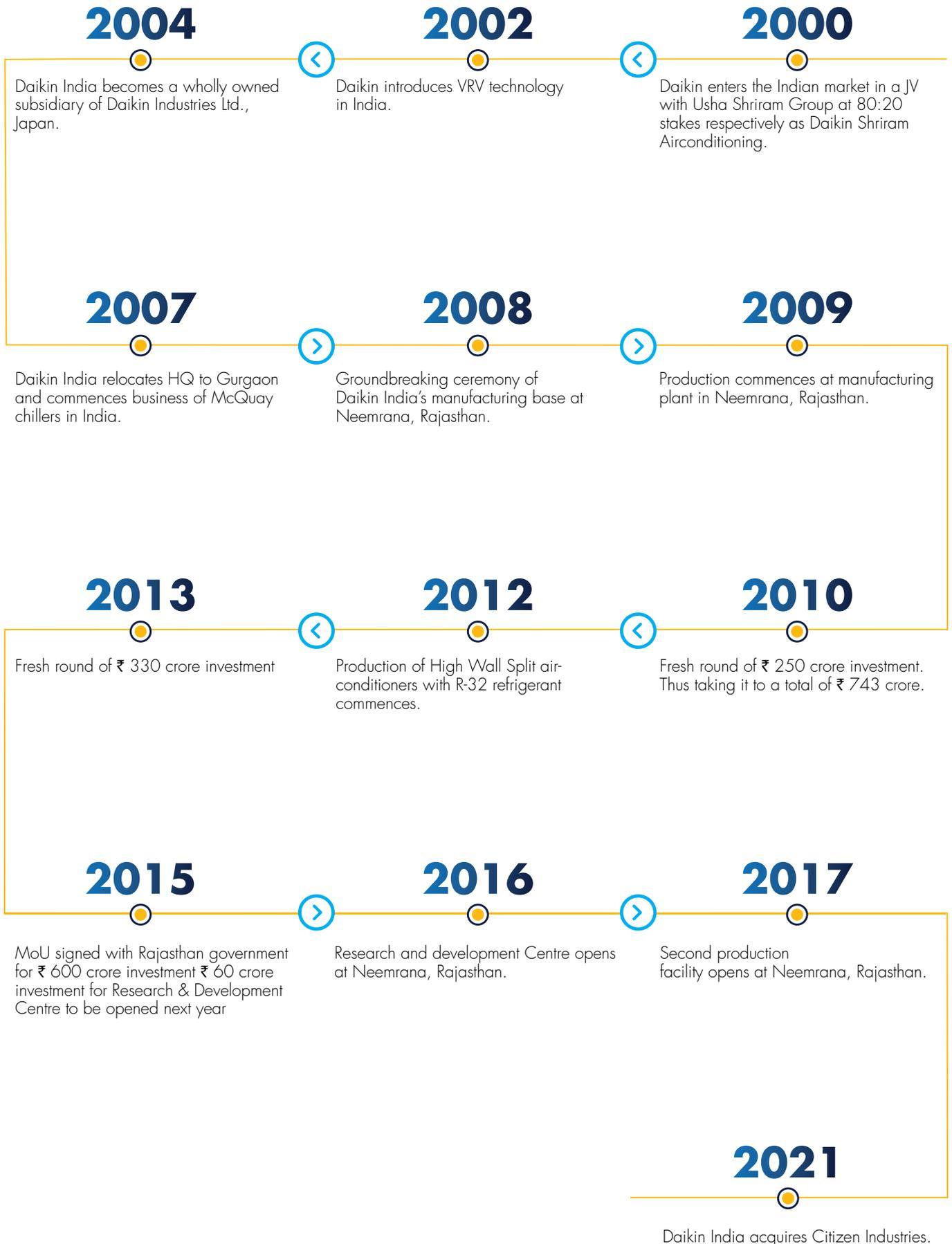

# ENGINE OF GROWTH

## MANUFACTURING PLANT

Daikin's manufacturing plant at Neemrana, Rajasthan, aims to create products that will add comfort to the lives of people. It is supported by a network of production bases throughout the world and showcases the application of advanced technology and equipment. Our comprehensive quality control system features centrally computerised management of quality and production data to facilitate high-quality production within scheduled time.

### AREA

**5,135** sq mtr

### INVESTMENTS\*

**10,299** Mn



FACTORY 1



FACTORY 2

## RESEARCH & DEVELOPMENT FACILITY

### Lab facilities

- Two Psychrometric Lab of 3 TR and one Lab of 5 TR
- One multi-chamber lab of 25TR capacity.
- One Full Anechoic chamber for running sound test
- 10 HP\* Product Reliability test lab, CFM test lab and one 11TR Psychrometric lab

### Test Facilities

- Cyclic Corrosion Test
- Salt Spray Test
- Thermal Shock Test\*
- Vibration Test\*
- Environmental Test\*
- Drop Test#

### Other Facilities

- Concept room
- Mock-up area
- Device test room (electronic parts test room)

\*Operational by 2018  
#Under installation

### AREA

**5,088** sq mtr

### INVESTMENTS\*

**1,000** Mn



R&D CENTRE



# BEFRIENDING THE ENVIRONMENT

AIR IS SOMETHING THAT SURROUNDS US 24 HOURS A DAY. IN FACT, OUR EXISTENCE, AS WELL AS EARTH'S DEPENDS ON IT. AT DAIKIN, THE FUTURE OF THE WORLD'S AIR IS OUR GREATEST CONCERN. WE, THE MANUFACTURER OF WORLD'S BEST AIR-CONDITIONERS, ARE ALWAYS PAVING THE PATH TO SAVE OUR ENVIRONMENT FOR NEXT GENERATION.

We phased out all R-22 model and shifted to the green refrigerant R-32. Now, whole world is coming together to find and work on way to address global warming issue. We are also offering worldwide free access to patents for equipment using next generation refrigerant, R-32. Refrigerant choice is a key in saving the ozone layer and reducing global warming.

R-32 is Environment-Friendly

**ZERO  
OZONE**

Depletion Potential

**1/3rd**

Global Warming Potential

**75%**

less carbon dioxide emissions

**BETTER LIFE**

cycle climate performance

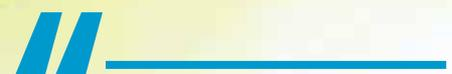

OUR RA MODELS  
MANUFACTURED  
IN INDIA USE THE  
NEXT GENERATION  
REFRIGERANT, R32.

R-32 offers superior performance

**15.3%**  
more cooling as compared to R410A

**~30%**  
refrigerant charging volume as compared to R410A & R22

**~5%**  
more power savings compared to R410A

**BETTER PERFORMANCE**  
at higher temperature as compared to R22 (Low Derating)

Only 1/3rd Global Warming potential

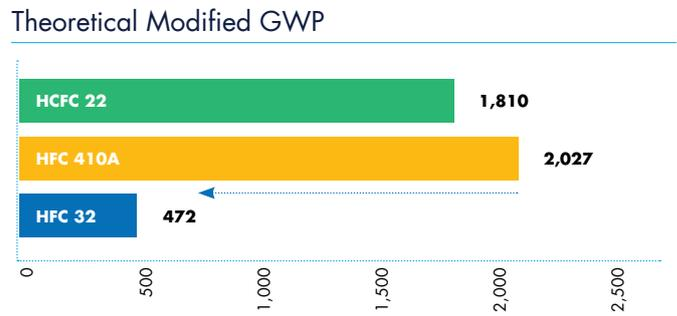
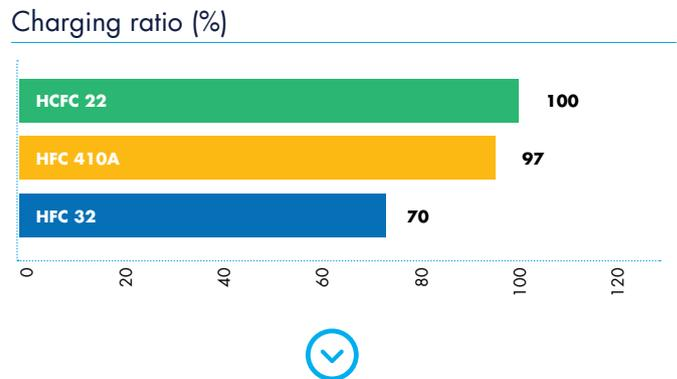
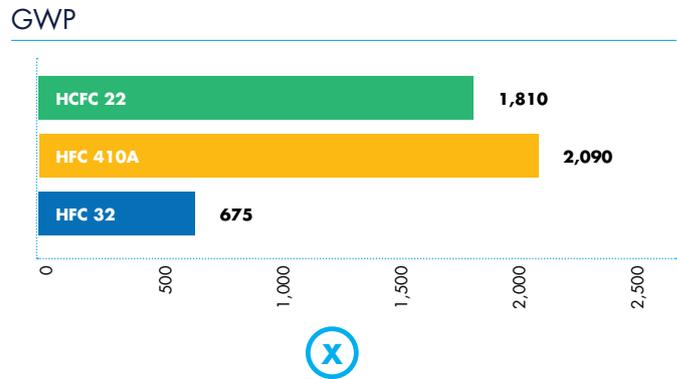

Most balanced refrigerant

HFC32

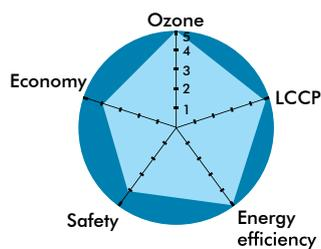

HFC410A

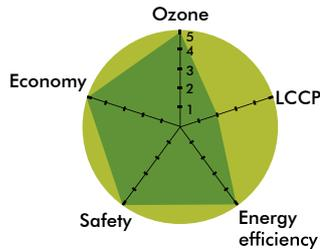

HFO1234YF

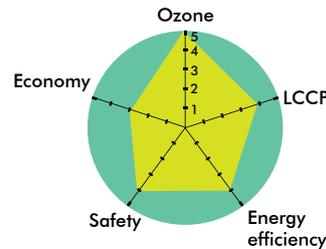

Propane (HFC290)

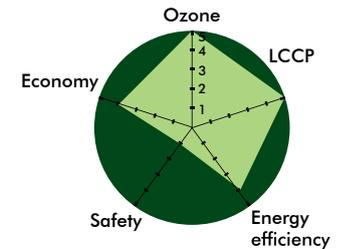

R-32 has zero Ozone Depletion Potential (ODP) and Modified Global Warming Potential (GWP) of 472, compared to R-410A's Modified GWP of 2,027. Also R-32 is a single component refrigerant, which makes it easy to recycle. It is because of these reasons that R-32 offers the lowest total emissions and best overall life-cycle climate performance



# **CEILING MOUNTED 3x3 ROUND FLOW CASSETTE TYPE**

**FCQF-A Series**  
Cooling Only



# FCQF-A SERIES

COOLING ONLY **R-32**



**FCQF-A PANEL**

**R-32**

New eight way discharge panel

Cooling Only

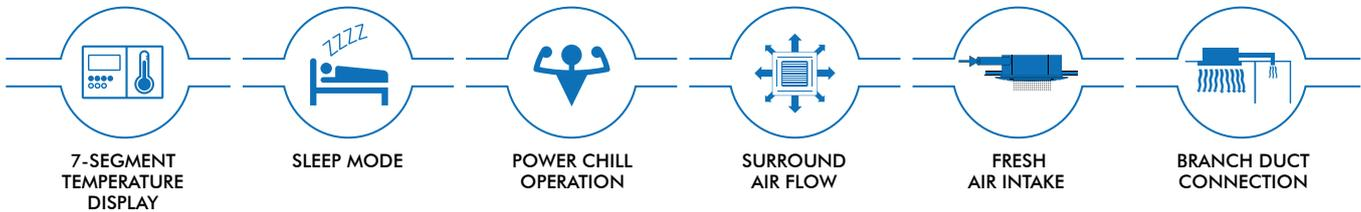

**FCQF18~42 (COOLING ONLY)<sup>1</sup>**      5.3 KW ~ 12.31KW      **R-32**

## ACCESSORY REQUIRED FOR INDOOR UNIT

### Wireless handset

**Standard**

**ARC91A154**  
(Cooling Only)

1 TR (Tons of Refrigeration) = 3.517 kW

## FEATURES

Main Function	Brief of Function
<b>ON/OFF</b>	To Start/Stop the Unit
<b>Mode</b>	Cool Mode
	Fan Mode
	Dry Mode
<b>Fan Speed</b>	Fan Speed Can be set to "Auto>Low>Low Medium>Medium>Medium High>High"
<b>Power Chill</b>	System will Operate at Maximum Efficiency for Powerful cooling for 20 Minutes .
<b>Swing</b>	Flaps will Start to swing /Stop at a Desired position.
<b>Good Sleep</b>	User Can Prevent Excessive Cooling of room during sleep.
<b>Coanda</b>	Directs airflow upwards.
<b>Econo</b>	This Operation enables efficient operation by limiting the power consumption.
<b>Timer</b>	ON Timer can be set from 1 hour to 12 hours
	OFF Timer can be set from 1 hour to 9 hours
<b>Display</b>	Display set temperature and error code in 7-Segment display in deco panel
<b>Child Lock</b>	Setting the Childlock disables all the buttons except the child lock .

### Surround Air Flow

There are four additional vents for air drafts at the corners of the panel that provide enhanced air coverage. With additional feature of automatic air swing, comfortable air can be delivered to high ceiling rooms.

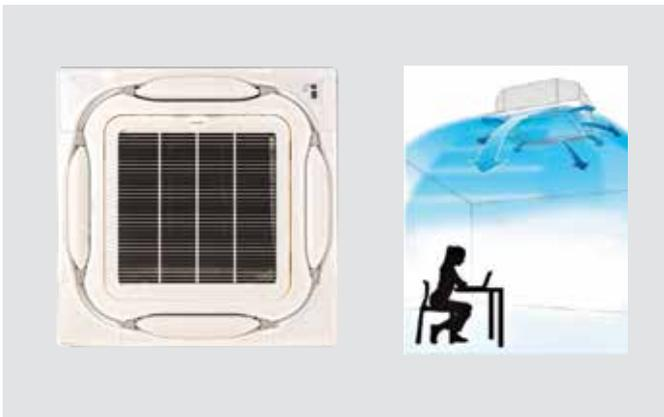

### Superior Sound Level

With the use of Daikin's latest technology turbo fan, cassette FCQF-A series is able to achieve exceptionally low noise level.

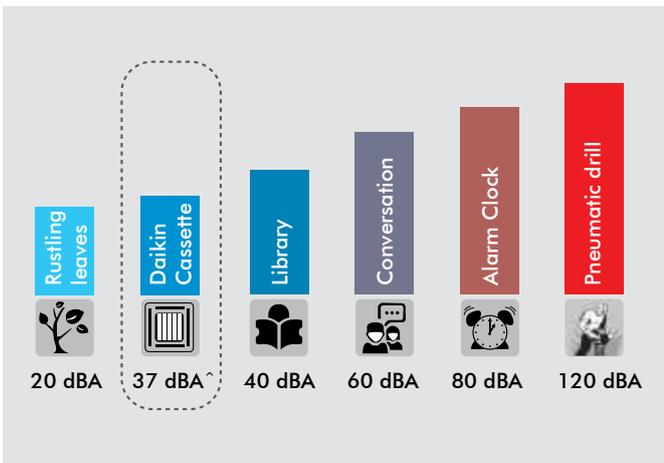

<sup>^</sup>refer to model size 1.5TR

### Forced On/Off Operation

Enables to operate the unit even if the remote controller is misplaced or the remote's battery is weak, just press the Forced On button for instant cooling comfort.



## WORK & SERVICING

### Fresh Air Intake

Keeps the introduction of fresh air intake within 20% of total air flow.

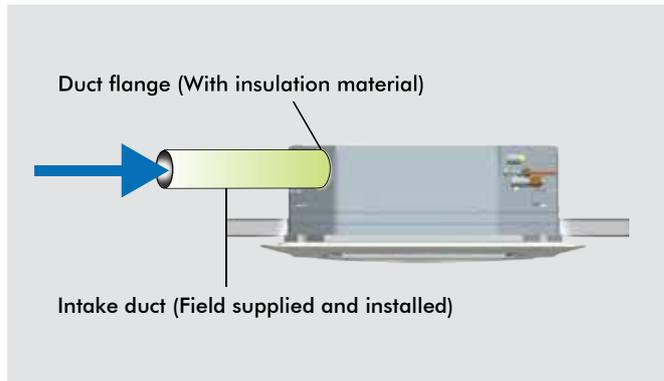

### Branch Duct Connection

Improves airflow distribution when there is an obstruction. It allows usage of air-conditioning for two rooms simultaneously.

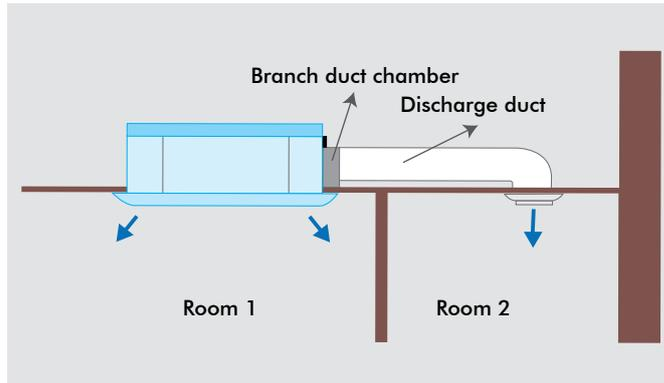

### Built-in High Head Drain Pump

The unit comes with a 700 mm built-in, high head drain pump. A safety float is incorporated in the drain pump to monitor its water level.

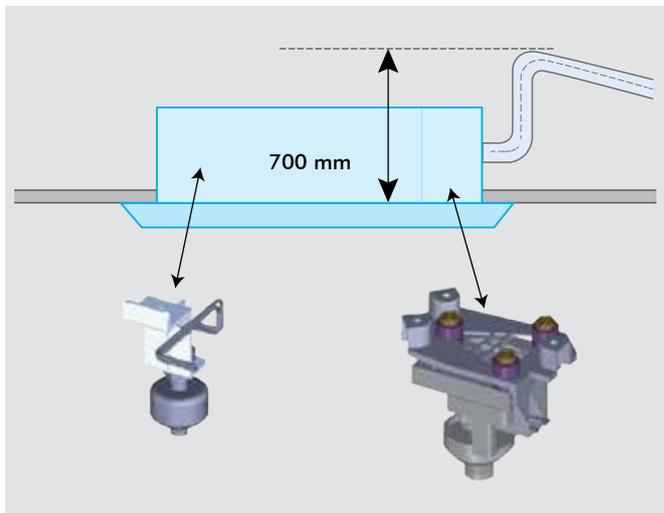

## FCQF SERIES (Contd.)

### CLEANLINESS

#### Silver ion anti-bacterial drain pan

A built-in antibacterial treatment that uses silver ion in the drain pan prevents the growth of slime, bacteria, and mould that cause odours and clogging.

(The lifespan of a silver ion cartridge depends on the usage environment, but should be changed once every two to three years.)



#### Non-flocking flaps

Flaps can be detached without use of tools. Condensation does not easily form and dirt does not cling to non-flocking flaps. They are easy to clean.



#### Filter has anti-mould and antibacterial treatment

Prevents mould and microorganisms growing out of the dust and moisture that adheres to the filters.

### QUICK AND EASY INSTALLATION

#### Lightweight

All models can be installed without using a lifter.

#### Installable in tight ceiling spaces

Standard panel

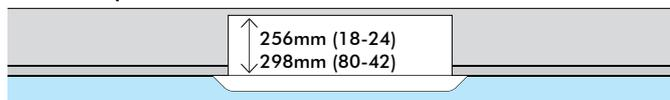

#### Easy height adjustment

Each corner of the unit has an adjuster pocket that lets you easily adjust the unit's suspended height.

*Note:*  
If the wireless remote controller is installed, a signal receiver unit is housed in one of the adjuster pockets

#### Easy hanging

Washer fixing plates secure washers in place and prevent washers from falling for easy installation.

Washer fixing plate  
Washer

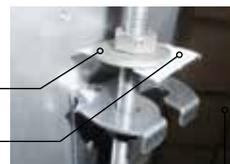

#### Easy removal of corner cover

It is possible to easily remove without use of screws or tools.

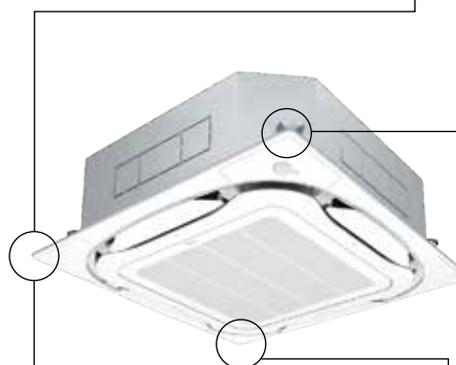

#### Ease in temporary hanging of decoration panel

In addition to the temporary hanging fixtures in 2 places normally used, corner part mounting fixtures in 4 places are provided.

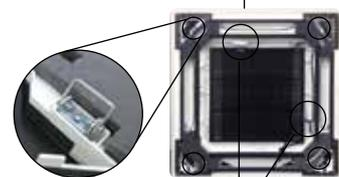
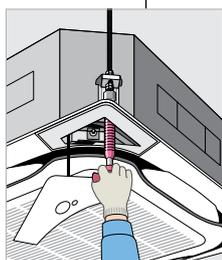

Corner part mounting fixtures (in 4 places)

Temporary hanging fixtures (in 2 places)

### Temporary placement of control box lid

Because the control box lid can be temporarily hung on the unit, there is no need to climb down the stepladder to retrieve it.

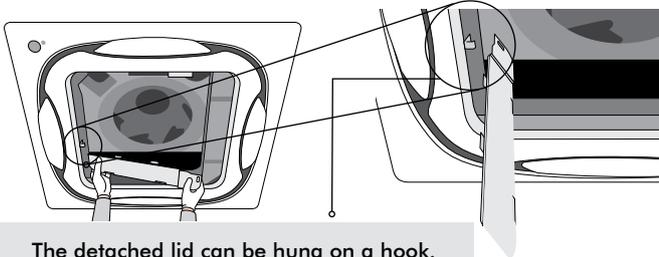

The detached lid can be hung on a hook.

### Installed in any direction

Since the orientation of the suction grille can be adjusted after installing, the direction of the suction grille lines can be unified when multiple units are installed.

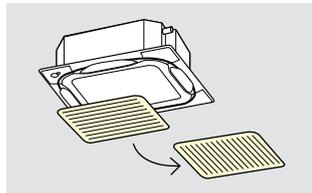

### Drain pump

Equipped as standard accessory with 850 mm lift.

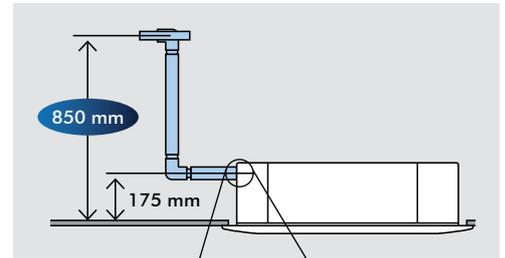

### Transparent drain sock



### Hanging height adjustment

Because the configuration of the hanger bracket changed, the dimensions from the ceiling to the hanger bracket also change during height adjustment for indoor unit.

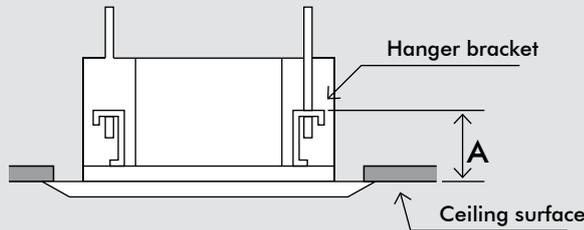

	A Dimensions
Standard panel	125-130mm

\*High-efficiency filter, ultra long-life filter, and fresh air intake

## EASY MAINTENANCE

### The condition of the drain pan and drain water

Can be checked by removing the suction grille and drain plug.

Drain outlet  
(with rubber plug)

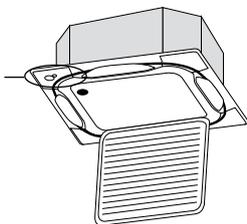

Just open the suction grille!

Note: For inquiries concerning auto grille panel installations, please contact your local dealer or Daikin representative

### 24 mm diameter drain outlet

The drain outlet allows insertion of a finger or dental mirror for inspection of the internal cleanliness of the drain pan. Removal of the suction panel enables access.



## FCQF SERIES (Contd.)

### Ultra long-life filter (option)

Maintenance is not required in normal shops or offices for up to four years.



## OPTIONS

Options required for specific operating environments

### Ultra long-life filter unit

Even in dusty environments where the air conditioning is constantly operating, the ultra long-life filter only has to be cleaned once a year.

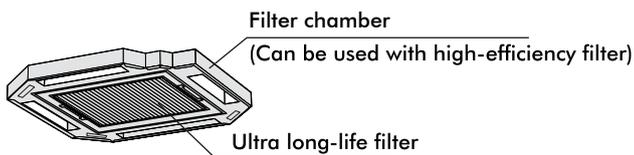

### Dusty area: annual filter change

\*For dust concentration of 0.3 mg/m<sup>3</sup> (Requires separately sold Air purifier.)  
1 year (Approx. 5,000 hr) = 15 hr/day x 28 day/month x 12 month/year

### Ordinary store or office: filter change every 4 years

\*For dust concentration of 0.15 mg/m<sup>3</sup>  
4 years (Approx. 10,000 hr) = 8 hr/day x 25 day/month x 12 month/years x 4 years

### High-efficiency filter unit

Available in two types: 65% and 90% colorimetry.

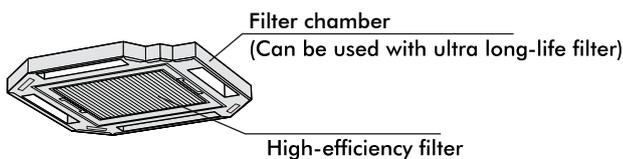

### Insulation kit for high humidity

Please use if you think the temperature and humidity inside the ceiling exceeds 30°C and RH 80%, respectively.

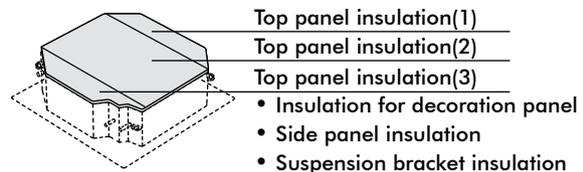

### Panel spacer

Use when only minimal space is available between drop ceilings and ceiling slabs.

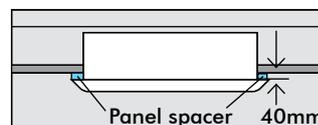

Note: Some ceiling constructions may hinder installation. Contact your Daikin Dealer before installing your unit.

### Sealing material of air discharge outlet

Sealing material block air discharge openings not used in 2-way or 3-way blow.

### Branch duct (direct-connection round duct)

A round duct can be attached without the need for a chamber.

A flanged port for direct connection of a round duct is provided. An existing branch duct chamber can also be fitted (square slit hole).

### Low gas pressure detection



### Fresh air intake kit

Using this kit, a duct can be connected to take in outdoor air. There are two chamber types that have intake in two places: with T-duct joint and without T-duct joint.

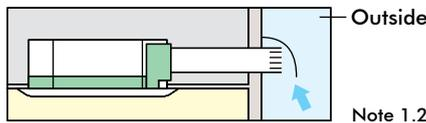

### The units can be installed in the following different ways

#### Chamber type (without T-duct joint)

**KDDP55B160**

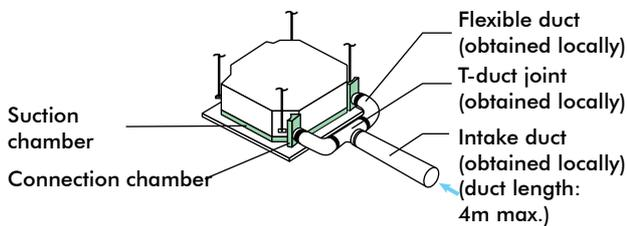

Note 3,4,5

#### Chamber type (with T-duct joint)

**KDDP55B160K**

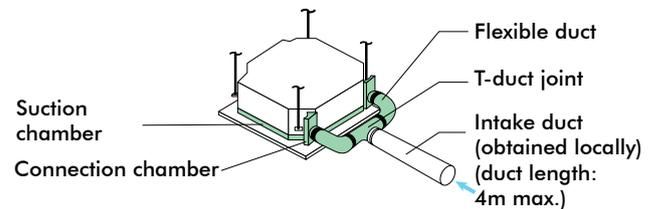

Note 3,4,5

#### Direct installation type (with T-duct joint)

**KDDP55X160A**

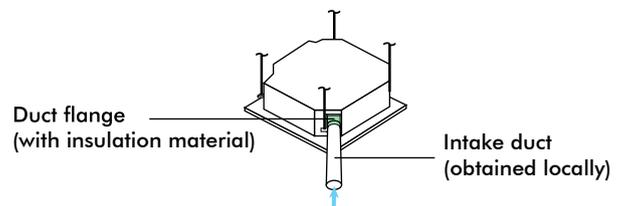

Note 6

**Note:**

1. Use of options will increase operating sound.
  2. Connecting ducts, fan, insect nets, fire dampers, air filters, and other parts should, as required, be obtained locally.
  3. When a local-obtained fan is used, an interlock with air conditioner is necessary. Optional PCB (KRP1C11A) is required for interlocking.
  4. When installing a fresh air intake kit (chamber type), two air outlet corners are closed.
  5. It is recommended that the volume of outdoor air introduced through the kit is limited to 10% of the maximum airflow rate of the indoor unit. Introducing higher quantities will increase the operating sound and may also influence temperature sensing.
  6. The volume of fresh air for direct installation type is approximately 1% of the indoor unit airflow.
- The chamber type is recommended when more fresh air is necessary.

# OUTDOOR UNITS

NON INVERTER | **R-32**



## COMPACT & QUIET

Equipped with scroll compressor for quieter operation

Smooth running, minimal vibration, low operating noise.



(\*Check technical manual for details)  
\*For 3.5TR model scroll compressor is available.



### A Series

dB(A)

Cooling Only Outdoor unit	Sound Level
RGVF18A	54
RGVF24A	56

# FUNCTION LINE UP

## DURABILITY

### Installation and maintenance

(Smoother and easier)

### Pre-charged for up to 7.5 metres (F-Series)

If refrigerant piping length does not exceed 7.5 m, there is no need for on-site gas charging.

### Drain pump mechanism

Steeper gradient realises more efficient condensate drainage. High-lift is especially useful for long lengths of drain piping.

### Pre-charged for up to 7.5 m

If refrigerant piping length does not exceed 7.5 m, there is no need for on-site gas charging.

### Long-life filter

Maintenance is not required for one year\*. The filter is washable and can be reused.

*\*For dust concentration of 0.15 mg/m<sup>3</sup>*

### Low gas pressure detection

Insufficient gas charging is normally hard to detect. During test run after installation and regular inspection, the refrigerant level is monitored by a microprocessor to maintain proper gas pressure. Reliability is assured and maintenance and inspection can be carried out more quickly.

### Emergency operation

Even if there is a malfunction elsewhere in the system, the fan or compressor can still be operated. (depending on the malfunction)

### Self-diagnosis function

The operating parameters of indoor and outdoor units, and sensor data at critical locations throughout the system, are constantly monitored using a microcomputer. To facilitate quick response in the event of a malfunction, a message appears on the LCD of the remote controller and an LED on the unit illuminates.

## CONTROL

### Auto-restart

If there is a power outage while the equipment is operating, operations will restart in the same mode as before the power cut when electricity is restored.

## OPTIONS

### High-efficiency filter

Two types are available: 65% and 90% colorimetry.

### Ultra long-life filter

Requires no maintenance for about 4 years\* (10,000h) in stores and offices.

*\*For dust concentration of 0.15 mg/m<sup>3</sup>*

### Fresh air intake kit

You can provide air-conditioning with fresh air from outside. Convenient for places where a ventilation fan cannot be installed.



# APPLICATION OF THE PRODUCT

## RETAIL



Versatility and control are the keys to create a comfortable condition within trading areas and changing rooms that will keep customers shopping. It's important to select a system that offers excellent performance, while minimising operating costs and energy consumption.

## OFFICES/BANKS



The challenge for an office or bank is the ability to effectively heat or cool open plan areas as well as meeting rooms. Cooling a meeting room when it is empty will mean running costs mount up unnecessarily. Conditions within open-plan areas are important for staff comfort levels.

## IT & SERVER ROOMS



Computer systems run round the clock and require a controlled temperature environment to operate effectively. Equipment in these rooms can generate a lot of heat and not removing the heat effectively can cause computer servers to malfunction. Downtime from inoperable servers can mean lost business and productivity.

## RESTAURANTS



Guests expect a perfect atmosphere, including comfortable conditions. Heat generated from lighting, the kitchen area and the dining area can all contribute to make restaurants uncomfortable with inadequate air-conditioning. Air-conditioning needs to be discreet and flexible to meet the demands of your restaurant and customers.



# CEILING CONCEALED TYPE

**FDB/MF Series**  
Cooling Only

# FDB/MF SERIES

COOLING ONLY **R-32**



ENHANCE THE DÉCOR OF YOUR ROOM WITH THE NEW UNOBTRUSIVE CONCEALED SERIES



<b>FDBF12~FDMF48 (COOLING ONLY)</b>	3.5 KW ~ 14.0 KW	COOLING	<b>R-32</b>
-------------------------------------	------------------	---------	-------------

## ACCESSORY REQUIRED FOR INDOOR UNIT

**WIRED HANDSETS**

Standard

**LCD type**  
(Applicable for FDB/MF)

**WIRELESS HANDSETS**

Optional

**BRC4N151**  
(Cooling Only)

## FEATURES

	Feature Details	Cooling Only
Comfort	Auto Fan Speed	•
	Auto Mode	—
	Auto Defrosting	—
	Dry Function	•
	Sleep Mode	•
IAQ	Washable Saranet Filter	•
Fin type	Anti Corrosion Hydrophilic Fin	• *2
	Wireless Controller	*1
Controller	Wired Controller	•
	24 Hour On/Off Timer	•
	Delay Timer	•
	Self Diagnosis Display	•
Protection	Auto Random Restart	•
	Hydrophilic Blue Fin Outdoor Heat Exchanger	•
Power supply	Power from Outdoor	•

\*1 Option

\*2 Outdoor units only

1 TR (Tons of Refrigeration) = 3.517 kW

## FEATURES FDMR(Q)N

### EXCELLENT AIR DISTRIBUTION

The conditioned air can be distributed evenly to every corner of the room through ducting. This helps to create a pleasant environment and maintain comfort. Furthermore, multiple areas can be conditioned simultaneously by using just one indoor unit.

### AUTO RANDOM RESTART WITH LAST-STATE-MEMORY

In the event of a sudden power failure during operation, unit restarts automatically in 64 different recovery timing patterns (within 180 seconds to 244 seconds) and the unit will operate based on the previous setting (operating mode, temperature setting and fan speed). This ensures that air-conditioners in the same building resume randomly instead of all units resuming at the same time, preventing power surge after a blackout.

### DOUBLE PROTECTION DRAINAGE SYSTEM

The primary drain pan is designed with high thermal insulation material and moulded in gradient for better condensate water drainage. The extra secondary drain pan 'built-in' to the standard unit offers extra protection against possible water leaking problems.

## FLEXIBILITY IN SYSTEM DESIGN

The unit offers fan motor that can operate up to 3 speeds, thus providing choices of external static pressure for designing ducting system.

## SELF DIAGNOSIS FEATURES

The microprocessor provides the possibility to detect and to diagnose any faults that occurs in the system. Faults are displayed as error code in the wired controller. This will ease the troubleshooting process.

## FEATURES FDB/MF

### WIDE EXTERNAL STATIC RANGE

Wide static range makes these series suitable to wide applications. Low static machines finds their application at space constraint areas i.e. Hotels and apartments. This series offering includes mid static machines also which meet the static requirements of long ducts and multi zones.

Refrigerant	Model Size (TR)	1.0	1.5	2.0	2.5	2.8	3.5	4.0
<b>R-32</b>	Static (Pa)	20	20	20	20	30	40	50

### LOW HEIGHT APPLICATION

New residential and commercial spaces, HVAC requirement are tilting towards low height indoor machines. FDBF range of low static machines with unit's height as low as 250 mm are the perfect match for low ceiling height installations.

Model Size (TR)	1.0	1.5	2.0	2.5	2.8	3.5	4.0
Unit Height (mm)	250	250	250	295	295	295	295

### QUIET OPERATION

Daikin ceiling concealed machines are designed to keep Enclosed area super quiet. Enclosed areas air-conditioned by FDBF machines are quieter than libraries.



\*Applicable for 1.0 TR model.

# OUTDOOR UNITS

NON INVERTER **R-32**



RGF12CRV1



RGF18CRV1/RGF24CRV1



RGF30CRV1/RGF36CRV1/RGF42CRY1/RGF48CRY1

## COMPACT & QUIET

- **EQUIPPED WITH SCROLL COMPRESSOR FOR QUIETER OPERATION**

Smooth running, minimal vibration, low operating noise.

# Upto 3.0 TR Rotary Compressor is available.  
# 3.5 TR & 4.0 TR Scroll Compressor is available.

## DURABILITY

- **INSTALLATION AND MAINTENANCE**

(Smoother and easier)

- **PRE-CHARGED FOR UP TO 7.5 METRES**

If refrigerant piping length does not exceed 7.5 m, there is no need for on-site gas charging.

# FUNCTION LINE UP

## ABUNDANCE OF FUNCTIONS THAT PROVIDE COMFORTABLE AIR-CONDITIONING IN STORES AND OFFICES.

- COMFORT

### SWITCHABLE FAN SPEED

High setting provides maximum reach while low setting minimises drafts.

### TIMER SELECTOR

Operation starts when the preset time of the ON timer elapses and stops when the preset time of the OFF timer elapses.

Simultaneously operates 2-4 indoor units with a single outdoor unit.

### PROGRAMME 'DRY'

Dehumidification is computer controlled to prevent abrupt and uncomfortable changes in air temperature. Useful for reducing discomforting humidity without uncomfortable cooling of the room.

### PE FIN

To achieve increased durability by improved resistance to salt corrosion and atmospheric pollution, coated PE fins (with special acryl pre-treatment) are used for the heat exchanger of the outdoor unit.

### HIGH-CEILING APPLICATION

Delivers air-conditioning comfort all the way down to the floor in air-conditioning zones with high ceilings.

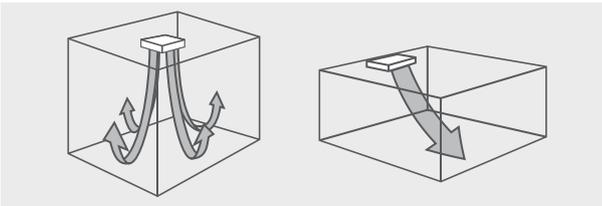

Note: When units are installed on high ceilings, depending on the model, various restrictions concerning maximum height, air discharge direction, and choice of options may apply.



- **WORK & SERVICING**

### LONG-LIFE FILTER

Maintenance is not required for one year (two years when a ceiling mounted cassette type is used).

### CEILING SOILING PREVENTION FUNCTION

Daikin's innovative air discharge mechanism keeps air flow away from the ceiling. Ceiling cleaning is less frequently required.

- **CONTROL FEATURES**

### AUTO-RESTART

If there is a power outage while the equipment is operating, operations will restart in the same mode as before the power cut when electricity is restored.

### ULTRA LONG-LIFE FILTER

Requires no maintenance for about 4 years\* (10,000 h) in stores and offices.

\*For dust concentration of 0.15mg/m<sup>3</sup>

### LOW GAS PRESSURE DETECTION

Insufficient gas charging is normally hard to detect. During post-installation trials and regular inspection procedures, the refrigerant level is monitored by computer to ensure proper gas pressure. Reliability is assured and maintenance and inspection can be carried out more quickly.

\*Available in 3 phase model (3.5 & 4 TR) only

### EMERGENCY OPERATION

If there is a malfunction elsewhere in the system, the fan or compressor can still be operated.

### SELF DIAGNOSIS FUNCTION

The operating parameters of indoor and outdoor units, and sensor data at critical locations throughout the system are constantly monitored using a microcomputer. To facilitate quick response in the event of a malfunction, a message appears on the LCD of the remote controller and an LED on the unit illuminates.

### FILTER SIGN

The filter sign warns you when it is time to clean the filter.

\*When using a wired remote controller the sign is displayed in the LCD. When using a wireless remote controller the filter sign lamp illuminates on the signal receiver unit.



# APPLICATION OF THE PRODUCT



## RETAIL

Versatility and control are the keys to create a comfortable condition within trading areas and changing rooms that will keep customers shopping. It's important to select a system that offers excellent performance, while minimising operating costs and energy consumption.



## OFFICES / BANKS

The challenge for an office or bank is the ability to effectively heat or cool open plan areas as well as meeting rooms. Cooling a meeting room when it is empty will mean running costs mount up unnecessarily. Conditions within open-plan areas are important for staff comfort levels.



## IT & SERVER ROOMS

Computer systems run round the clock and require a controlled temperature environment to operate effectively. Equipment in these rooms can generate a lot of heat and not removing the heat effectively can cause computer servers to malfunction. Downtime from inoperable servers can mean lost business and productivity.



## RESTAURANTS

Guests expect a perfect atmosphere, including comfortable conditions. Heat generated from lighting, the kitchen area and the dining area can all contribute to make restaurants uncomfortable with inadequate air-conditioning. Air-conditioning needs to be discreet and flexible to meet the demands of your restaurant and customers.



# TECHNICAL SPECIFICATIONS-3X3 Cassette Type

**R-32**

UNIT	PRODUCT CATEGORY		CASSETTE SERIES				
	Product Class	-----	18	24	30	36	42
Nominal Capacity	TR	1.5	2.0	2.5	3.0	3.5	
Rated Capacity	KW	5.30	7.03	8.79	10.50	12.31	
Rated Capacity	BTU/Hr	18000	24000	30000	36000	42000	
Rated Power Input	KW	1.45	1.93	2.41	3.04	3.80	
COP			3.65		3.45	3.24	
Star Applicable (As per KS2463-2019)	-----	3 Star	3 Star	3 Star	2 Star	1 Star	
Operating Range	IDU (DB)°C	19~35					
Operating Range	ODU (DB)°C	19~48					
Model Number	-----	<b>FCQF18ARV1</b>	<b>FCQF24ARV1</b>	<b>FCQF30ARV1</b>	<b>FCQF36ARV1</b>	<b>FCQF42ARV1</b>	
Casing Size	HXWXD(MM)	256X840X840			298X840X840		
Power Supply	V/Hz/Ph	220-240V/50/1ph					
Air Flow Rate (High)	CFM/(H)	812		1218		1288	
Fan Speed	No	5					
Sound Pressure Level (High)	(dBA)	37		45		46	
Net Weight	Kg	22		24			
Piping Connection(Liquid)	mm	6.35(Dia)			9.5(Dia)		
Piping Connection(Gas)	mm	12.7(Dia)		15.9(Dia)			
Drain	mm	32(External Dia)/25(Internal Dia)					
Model Number	-----	BYCQ48EAF					
Casing Color	-----	FRESH WHITE					
Size	mm	50X950X950					
Weight	kg	5.5					
Wireless(Standard)	-----	ARC91A154					
Wired	-----	Not Available					
Model Number	-----	<b>RGVF18ASV1</b>	<b>RGVF24ASV1</b>	<b>RGVF30ASV1</b>	<b>RGVF36ASV1</b>	<b>RGVF42ASV1</b>	
Casing Size (HXWXD)	mm	595X845X300			990X940X320		
Power Supply	V/Hz/Ph	220-240V/50/1ph					
Max Total Pipe Length	Mtr.	20					
Max Vertical Pipe Length	Mtr.	10					
Std. Pipe Length	Mtr.	7.5					
Sound Pressure Level	(dBA)	54	56	58	63		
Precharge & Service Valve	Yes/No	Yes					
Protection Device	-----	Inbuilt TOP, Comp & Motor				LP/HP/SPPR/UV/OV	
Piping Size (mm)		6.4 (Dia)		9.5(Dia)			
Refrigerant Type	-	R-32					
Refrigerant Charge	kg	1.09	1.21	2.21	2.65	2.05	
Compressor Type	Type	Rotary				Scroll	
Accumulator	-----	Part of Compressor					
HE Type/Coating	Type	FTHX (Pre Coated)					
Net Weight (Approx)	kg	36	45	63	65	69	
Installation Kit	Yes/No	No					

Note:

1. Rated cooling capacities are based on the following conditions: Return air temp.: 27°CDB, 19.0°CWB, Outdoor temp.: 35°CDB, 24°CWB Equiv. ref. piping: 7.5m (Horizontal)

2. Anechoic chamber conversion value, measured under JIS conditions. During actual operation, these values are normally somewhat higher as a result of ambient conditions.

\*\*Star Rating as per Energy & Petroleum Regulatory Authority (EPRA) Kenya Bureau of Standards (KEBS)

\*Due to continuous R&D, Technical Specification, features, Product image may change.

# TECHNICAL SPECIFICATIONS-Ceiling Concealed Duct Type

**R-32**

UNIT	Product Category	Unit	LSP DUCT SERIES TYPE				MSP DUCT SERIES TYPE			
			Nominal Capacity	TR	1.0	1.5	2.0	2.5	2.8	3.5
Rated Capacity	Watt	3516	5274	7032	8790	9845	12306	14064		
Rated Capacity	BTU/Hr	12000	18000	24000	30000	33600	42000	48000		
Rated Power Input	Watt	1090	1740	2050	2710	3120	3950	4630		
COP	W/W	3.23	3.03	3.43	3.24	3.16	3.12	3.04		
Operating Range	IDU (DB/WB)°C	19/14~35/24				19/14~35/24				
	ODU	19~48				19~48				
Model Number	-----	<b>FDBF12CRV1</b>	<b>FDBF18CRV1</b>	<b>FDBF24CRV1</b>	<b>FDMF30CRV1</b>	<b>FDMF36CRV1</b>	<b>FDMF42CRV1</b>	<b>FDMF48CRV1</b>		
Casing Size (HXWXD)	MM	250X880X605		250X1130X605		295X1430X665		295X1730X665		
Power Supply	V/Hz/Ph	220-240V/50/1ph					220-240V/50/1ph			
Air Flow Rate (High)	CFM	400	600	800	1000	1200	1400	1500		
ESP	Pa	20			20	30	40	50		
Fan Speed	No	3								
Sound Pressure Level (High)	(dBA)	38	41	43	43	46	47	49		
Remote Controller (With IDU)	-----	Wired Type-Standard								
Net Weight	Kg	31	31	34	50	55	55	69		
Model Number	-----	<b>RGF12CRV1</b>	<b>RGF18CRV1</b>	<b>RGF24CRV1</b>	<b>RGF30CRV1</b>	<b>RGF36CRV1</b>	<b>RGF42CRV1</b>	<b>RGF48CRV1</b>		
Casing Color	-----	IVORY WHITE					IVORY WHITE			
Casing Size (HXWXD)	mm	550X765X285		595X845X300		990X940X320				
Power Supply	V/Hz/Ph	220-240V/50/1ph					220-240V/50/1ph			
Max Total Pipe Length	Mtr.	20					30			
Max Vertical Pipe Length	Mtr.	10					15			
Std. Pipe Length	Mtr.	7.5					7.5			
Sound Pressure Level	(dBA)	51	54	56	58			60		
Pre charge & Service Valve	YES/NO	Yes					Yes			
Protection Device	-	Inbuilt TOP Comp & Motor				Inbuilt TOP Comp & Motor		LP/HP/SPPR/UV/OV		
Piping Size (mm)	Gas	12.7		15.9		15.9				
	Liquid	6.4					9.5			
Refrigerant Type	-----	R-32								
Refrigerant Charge	Kg	0.72	0.68	1.16	1.41	2.235	1.92	1.835		
Compressor Type	Type	Rotary				Rotary		Scroll		
Accumulator	-----	Part of Compressor					Part of Compressor			
HE Type/Coating	Type	FTHX(Precoated)					FTHX(Precoated)			
Net Weight (Approx)	Kg	30	36	45	63	65	69	70		
Installation Kit	YES/NO	No					No			

Note :

1. Rated cooling capacities are based on the following conditions: Indoor temp., 27°CDB, 19.0°CWB; outdoor temp. 35°CDB, 24°CWB. Equiv. refrigeration piping, 7.5 m (horizontal).

2. Rated heating capacities are based on the following conditions: Indoor temp., 20°CDB, outdoor temp., 7°CDB, 6°CWB. Equiv. refrigeration piping, 7.5 m (horizontal)

3. Initial setting is standard.

4. Anechoic chamber conversion value, measured according to JIS parameters and criteria. During operation these values are somewhat higher owing to ambient conditions.

\*Due to continuous R&D, Technical Specification, features, Product image may change.

# REASONS TO BUY DAIKIN



## Air-conditioning specialist from Japan

Daikin focuses on air-conditioning solutions and control systems. As specialists, it's all we do. No wonder Daikin is recognised as an expert in air-conditioning.



## High energy efficiency

Daikin's continuous drive for improved efficiency has seen its advanced inverter technology being applied to split, ducted and other systems. These systems provide a more comfortable environment and are more energy efficient when compared to non-inverter systems.



## Environment friendly

Daikin continues to work towards a sustainable future, and has received Environmental Management System certification to ISO14001. Daikin Airconditioning India Pvt. Ltd. is dedicated to preserving and protecting the environment through the production of energy efficient products.



## The Daikin edge with in-house manufacturing

Daikin is the only company in the world dedicated to manufacturing both air-conditioning systems and refrigerants. Each element has been designed to work flawlessly with the next - delivering optimal performance - from the time a project begins till the moment of absolute comfort.



## Experienced dealers

Daikin distributes its products through experienced dealers. This ensures that you receive a top quality product with expert support. Together this means the best air-conditioning solution for your individual needs.



## Pioneer in air-conditioners

Daikin has been providing air-conditioning solutions for over 15 years in India. As one of the industry's more trusted names, Daikin air-conditioning equipment can be found in homes, offices, hotels and shops. Daikin is committed to the air-conditioning market and has a manufacturing facility located in Rajasthan.



## Wise investment – Low running cost

When you buy a Daikin air-conditioning system you need to look beyond the initial purchase price. It pays to consider ongoing running costs in conjunction with the potential life of the product. Daikin systems offer superior build quality and energy efficiency.



## Comprehensive range and quiet operation

Daikin has a comprehensive range of products in both domestic and commercial segments. Designed to provide effective and quiet air-conditioning, Daikin can customise a solution to meet every requirement.





---

#### Contact Address

#### **DAIKIN AIRCONDITIONING INDIA PVT.**

#816, 8th Floor  
Purshottam Place  
Delta Tower 1, Westland  
Nairobi, Kenya  
Tel : +254-20-515-4028  
Visit us at <https://www.daikineastafrica.com/>  
Email: [customerservice@daikinindia.com](mailto:customerservice@daikinindia.com)

---

**f/daikineastafrica**

#### Disclaimer

As a continuing policy of product innovation at Daikin, the design and specifications are subject to change without prior notice. The visuals of the products in the brochure are representative only, actual products might differ from the ones shown.